

PHILTEC
FIBEROPTIC SENSORS



D I S T A N C E | D I S P L A C E M E N T | V I B R A T I O N

Product Catalog

January 2012

PHILTEC

www.philtec.com

Fiberoptic Sensors for the Measurement of Distance, Displacement and Vibration



Type D Analog Output



10DMS Rack



muDMS USB Output



Type RC Analog Output

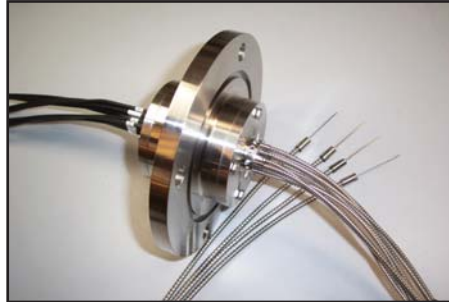

Vacuum Passthru



mDMS RS232 Output

How To Build A Sensor

1. Choose D or RC type
 - based upon *Direction of Target Motion*
2. Select Model Based Upon
 - Range of Motion
 - Standoff Distance
 - Resolution
 - Target Spot Size
3. Select Sensor Tip Design
4. Select Fiberoptic Cable Materials To Suit Application
5. Connectorize The System As Desired
6. Select Analog or Digital Output Package

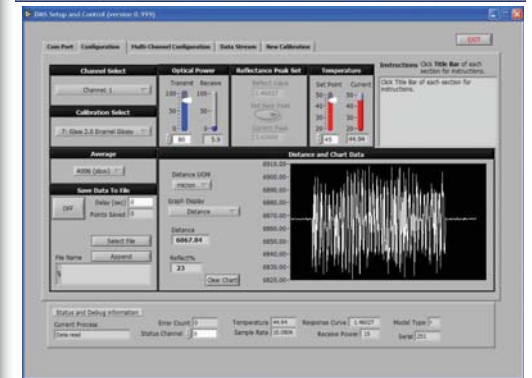
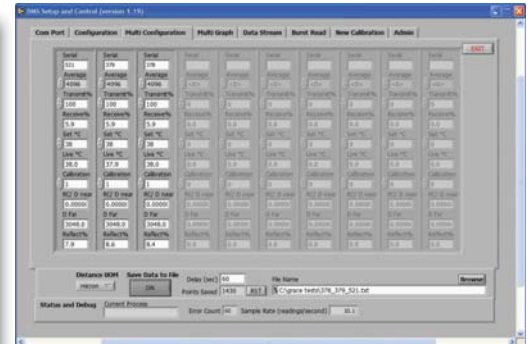

DMS Control Software

PHILTEC

www.philtec.com

Precision Dynamic Measurements

Foreward

Thank you for your interest in our products. Philtec has been providing innovative fiberoptic displacement sensing solutions since 1988.

This catalog gives specifications for standard sensor models, standard sensor options and accessories.

WE CUSTOMIZE.....please contact the factory for custom fiberoptic designs. Our engineers can help you design that special sensor uniquely meeting your application requirements....

Overview....

Philtec's non-contact FIBEROPTIC DISPLACEMENT SENSORS measure linear distances from 0 to 2 inches away (50mm), are intrinsically safe and very compact, allowing measurements inside mechanisms, submerged in fluids, in extreme environments and with targets that are difficult to measure with other sensing technologies.

Two types of fiberoptics are available:

Reflectance Dependent (**D**) and Reflectance Compensated (**RC**)

D models are commonly used for single axis vibration and stroking motions.

RC models are good for single axis measurements as well as for measurements to objects translating or rotating past the sensor. *Either type can be provided with an analog or a digital output.*

Analog Sensors...excel in dynamic applications with bandwidths exceeding 1 megahertz.

Digital Sensors...best choice for precision gaging applications with a 5 KHz maximum sampling rate.

Principle of Operation....

These are retro-reflective type optical devices. The sensors use bundled glass fibers to transmit light to and receive reflected light from target surfaces. The intensity of the reflected light is proportional to the distance between the sensor tip and the target surface.

Fiberoptic Cables....

Standard units are produced using glass fibers which are limited to a maximum temperature of 480°C.

*Quartz fibers are available for temperature applications to 600°C and higher.

*Quartz fibers are also required for operation in high radiation environments.

* Please contact the factory for technical support and pricing.

SENSOR SYSTEM CONFIGURATIONS

Four types of sensor system configurations can be produced:

1. **One Part Systems** - the fiberoptic cable is not detachable from the amplifier.
2. **Two Part Systems** - have a cable or amplifier bulkhead mounted connector.
3. **Three Part Vacuum Passthru Systems** - have a separate vacuum passthru flange.
4. **Three Part Extension Cable Systems** - have two cable connectors.

Model numbering examples:

1. D100
2. D100-B (in-line) or D100-B1 (bulkhead)
3. D100-Bv2
4. D100-B(2)

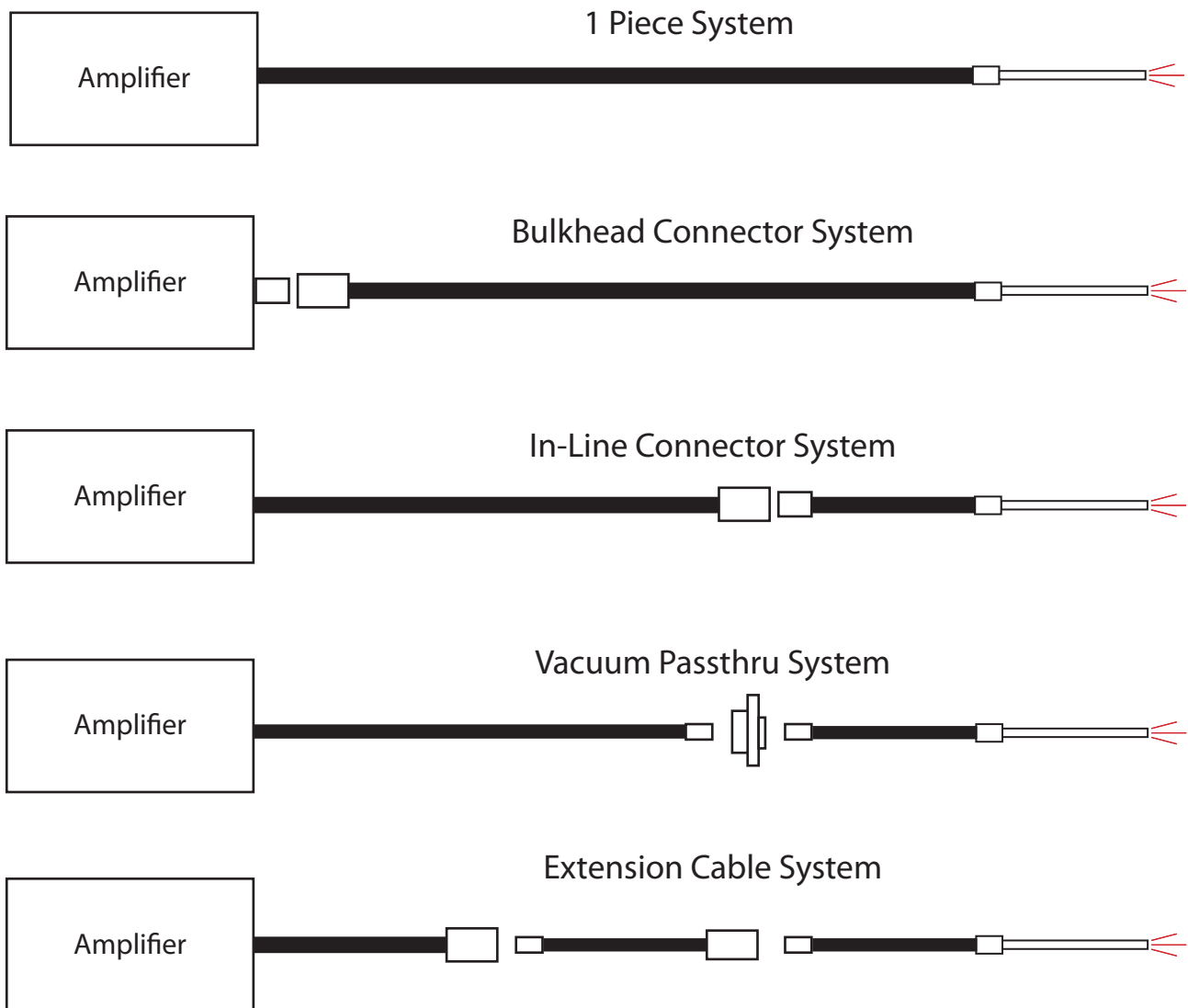

FIBEROPTIC DISPLACEMENT SENSORS

with ANALOG OUTPUT

Standard single channel units include amplifier and sensor tip with 914 mm long (3 foot) fiberoptic cable, require +12 VDC input power, and provide 0 to +5 volt analog output with DC - 20 KHz bandwidth.

D MODELS REFLECTANCE DEPENDENT		
MODEL	Operating Range	
	mm	mINCH
D6	1	40
D12	2	80
D20	1.25	50
D21	2	80
D47	5	200
D63	3	120
D64	6	240
D100	10	400
D125	15	600
D169	19	750
D170	30	1200
D171	50	2000



MODEL NUMBER FORMAT:

D6-AB1C1

The basic model number is followed by the letters in alphabetical order designating sensor options.

RC MODELS REFLECTANCE COMPENSATED		
MODEL	Operating Range	
	mm	mINCH
RC12	0.4	16
RC20	1.25	50
RC25	0.76	30
RC60	3.2	125
RC62	2	80
RC63	4	160
RC90	9	350
RC100	5	200
RC140	6	250
RC171	12.7	500
RC190	21	825

OPTIONS FOR ANALOG SENSORS

FOR D MODELS	FOR RC MODELS	OPTION CODE	FEATURE
√	√	A	PROVIDES TEMPERATURE STABILIZED ELECTRONICS FOR LOW DRIFT/HIGH ACCURACY
√	√	B	CONNECTORIZES SENSOR SYSTEM WITH IN-LINE CONNECTOR. (D6, RC12 n/a). <i>*OPTION B IS ALSO REQUIRED FOR USE WITH VACUUM PASSTHRU FLANGES & ASSEMBLIES Bv2, Bv3, Bv4, BvF</i>
√	√	B1	CONNECTORIZES SENSOR SYSTEM WITH BULKHEAD CONNECTOR (D6 n/a)
√	√	Bv1	CONNECTORIZES SENSOR SYSTEM WITH SINGLE CHANNEL VACUUM PASSTHRU HARDWARE FOR 1 E-7 TORR (1 nPa). INCLUDES ULTRA-TORR COMPRESSION FITTING (D6, RC12 n/a)
√	√	Bv133	SAME AS Bv1 WITH 1.33" DIAMETER MINI-CF TYPE FLANGE FOR BULKHEAD MOUNTING
√	N/A	Bv2	2 PORT SINGLE CHANNEL VACUUM PASSTHRU FLANGE FOR D MODELS FOR 10 E-11 TORR (10 pPa) (D6 n/a) <i>*Requires Option B</i>
N/A	√	Bv3	3 PORT SINGLE CHANNEL VACUUM PASSTHRU FLANGE FOR RC MODELS FOR 10 E-11 TORR (10 pPa) (RC12 n/a), <i>*Requires Option B</i>
√	N/A	Bv4	4 PORT DUAL CHANNEL VACUUM PASSTHRU FLANGE FOR D MODELS FOR 10 E-11 TORR (D6 n/a) <i>*Requires Option B</i>
√	√	BvF	MULTI-CHANNEL HIGH VACUUM PASSTHRU ASSEMBLY FOR 10 E-7 TORR (1 pPa). CAN ACCOMMODATE EIGHT D TYPE OR FIVE RC TYPE SENSORS. (D6, RC12 & RC20 n/a) <i>*Requires Option B</i>
√	√	C1	INTERLOCKING STAINLESS STEEL SHEATHING FOR FIBEROPTIC CABLES
√	√	C2	SILICONE TUBING SHEATHING FOR FIBEROPTIC CABLES
√	√	C3	SILICONE TUBING OVER PTFE WRAP SHEATHING FOR FIBEROPTIC CABLES
√	√	C4	SILICONE TUBING OVER STEEL MONOCOIL SHEATHING FOR FIBEROPTIC CABLES
√	√	C5	PTFE OVER STAINLESS STEEL INTERLOK SHEATHING FOR FIBEROPTIC CABLES
√	√	C6	PVC OVER NYLON WRAP SHEATHING FOR FIBEROPTIC CABLES
√	√	C7	PTFE TUBING SHEATHING FOR FIBEROPTIC CABLES

OPTIONS FOR ANALOG SENSORS

FOR D MODELS	FOR RC MODELS	OPTION CODE	FEATURE
√	√	C8	PVC SHRINKWRAP SHEATHING FOR FIBEROPTIC CABLES
√	√	C9	ANNEALED (semi-rigid) STAINLESS STEEL TUBING FOR FIBEROPTIC CABLES
√	√	C10	SILICONE OVER SS INTERLOK SHEATHING FOR FIBEROPTIC CABLES
√	√	C11	POLYOLEFIN HEAT SHRINK TUBING, MOISTURE/VAPOR BARRIER FOR FIBEROPTIC CABLES
N/A	√	D	REFLECTANCE DEPENDENT OUTPUT ADDED TO RC SENSOR
√	√	E	EXTRA LENGTH OF FIBEROPTIC CABLE (some models limited to 10 Feet, some models limited to 49 Feet)
√	√	Fv1	LOW VACUUM PASSTHRU FOR 10 E-4 TORR (1000 mPa). PROVIDES SOLID SECTION ON FIBEROPTIC CABLE, COMPRESSION FITTING, AND STAINLESS STEEL INTERLOK SHEATHING ON VACUUM SIDE
√	√	Fv2	LOW VACUUM PASSTHRU, SAME AS Fv1, PROVIDES Ø 0.250" X 3"L SOLID SECTION ON FO CABLE
√	√	Fv3	LOW VACUUM PASSTHRU, SAME AS Fv1, PROVIDES Ø 0.500" X 3"L SOLID SECTION ON FO CABLE
√	√	G1	ADDITIONAL OUTPUT, DC COUPLED WITH 10x GAIN and ADJUSTABLE DC OFFSET
√	√	G2	ADDITIONAL OUTPUT, AC COUPLED WITH 10x GAIN
√	N/A	H1	HIGH FREQUENCY AMPLIFIER FOR D MODELS UP TO 200 KHZ BANDWIDTH
√	N/A	H2	HIGH FREQUENCY AMPLIFIER FOR D MODELS ABOVE 200 KHZ TO 1 MHZ BANDWIDTH
N/A	√	H3	HIGH FREQUENCY AMPLIFIER FOR RC MODELS UP TO 350 KHZ BANDWIDTH
√	N/A	+H1	ADDITIONAL OUTPUT FOR D MODELS WITH BANDWIDTHS UP TO 200 KHZ
√	N/A	+H2	ADDITIONAL OUTPUT FOR D MODELS WITH BANDWIDTHS EXCEEDING 200 KHZ UP TO 1 MHZ
N/A	√	+H3	ADDITIONAL OUTPUT FOR RC MODELS WITH BANDWIDTHS UP TO 350 KHZ
√	√	L	LOW FREQUENCY AMPLIFIER (< 20 KHz), 100 Hz STD
√	√	+L	ADDITIONAL OUTPUT WITH LOW FREQUENCY BANDWIDTH (< 20 KHz), 100 Hz STD
√	√	M	DIGITAL DISPLAY - DC VOLTS
N/A	√	N	LOW NOISE AMPLIFIER (RC sensors only)
√	√	O	ADJUSTABLE DC OFFSET
√	√	P	POLYNOMIAL CURVE FIT TO SPECIFIED CALCULATION RANGE
√	√	Q	CONNECTORIZED AC/DC POWER ADAPTOR AND BNC OUTPUT
√	√	R	AMBIENT LIGHT REJECTION
√	N/A	S	SIDE-VIEWING SENSOR TIP
√	√	T1	CUSTOMIZED SENSOR TIP, STRAIGHT
√	√	T2	CUSTOMIZED SENSOR TIP, STRAIGHT and THREADED
√	√	T3	CUSTOMIZED SENSOR TIP, NON-METALLIC
√	√	T4	SIMPLE RIGHT ANGLE TIP
√	√	T5	SQUARE BODY RIGHT ANGLE TIP, UNTHREADED
√	√	T6	SQUARE BODY RIGHT ANGLE TIP, THREADED
√	√	T7	SPECIAL TIP MADE TO CUSTOMER SPECIFICATIONS
√	√	T8	HIGH TEMPERATURE TIP, 350°C MAX.
√	√	T9	HIGH TEMPERATURE TIP, 482°C MAX.
√	√	T10	CUSTOMIZED SENSOR TIP, METALLIC BUT NON-MAGNETIC
√	√	T11	INVAR PROBE TIP FOR LOW EXPANSION COEFFICIENT
√	√	V	PROVIDES SENSOR AMPLIFIER WITH 0 - 10 VOLT OUTPUT
√	√	W	WINDOW PROBE FOR HIGH PRESSURE OR VACUUM
√	√	Wb	SAPPHIRE WINDOW BRAZED TO SENSOR TIP FOR HIGH PRESSURE OR VACUUM

DMS - DISPLACEMENT MEASUREMENT SYSTEMS

with RS232 OUTPUT

Standard units can be operated locally via keypad or remotely via RS232. They have a 152 x 102 x 57 mm (6 x 4 x 2.25 inch) electronics package with 2-line display. Dual-channel units can display single or dual channel readings. Price includes RS232 cable, Philtec DMS Setup and Control Software, Labview™ drivers, a sensor tip with 3 foot long fiberoptic cable and AC/DC power adaptor. All units have full-featured capability for:

- Amplifier Temperature Stabilization
- Peak-to-Peak Amplitudes
- Calibration Scaling & Storage
- Tared Readings
- Data Averaging
- Total Runout, T.I.R.
- 5,000 Samples/Sec Max. per RS232 port



REFLECTANCE DEPENDENT

MODEL	Operating Range	
	mm	mINCH
DMS-D6	1	40
DMS-D12	2	80
DMS-D20	1.25	50
DMS-D21	2	80
DMS-D47	5	200
DMS-D63	3	120
DMS-D64	6	240
DMS-D100	10	400
DMS-D125	15	600
DMS-D169	19	750
DMS-D170	30	1200
DMS-D171	50	2000

SINGLE CHANNEL UNITS

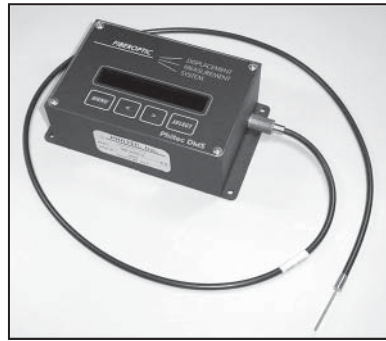

RC MODELS REFLECTANCE COMPENSATED

MODEL	Operating Range	
	mm	mINCH
DMS-RC12	0.4	16
DMS-RC20	1.25	50
DMS-RC25	0.76	30
DMS-RC60	3.2	125
DMS-RC62	2	80
DMS-RC63	4	160
DMS-RC90	9	350
DMS-RC100	5	200
DMS-RC140	6	250
DMS-RC171	12.7	500
DMS-RC190	21	825

REFLECTANCE DEPENDENT

MODEL	Operating Range	
	mm	mINCH
2DMS-D6	1	40
2DMS-D12	2	80
2DMS-D20	1.25	50
2DMS-D21	2	80
2DMS-D47	5	200
2DMS-D63	3	120
2DMS-D64	6	240
2DMS-D100	10	400
2DMS-D125	15	600
2DMS-D169	19	750
2DMS-D170	30	1200
2DMS-D171	50	2000

DUAL CHANNEL UNITS



RC MODELS REFLECTANCE COMPENSATED

MODEL	Operating Range	
	mm	mINCH
2DMS-RC12	0.4	16
2DMS-RC20	1.25	50
2DMS-RC25	0.76	30
2DMS-RC60	3.2	125
2DMS-RC62	2	80
2DMS-RC63	4	160
2DMS-RC90	9	350
2DMS-RC100	5	200
2DMS-RC140	6	250
2DMS-RC171	12.7	500
2DMS-RC190	21	825

Mini-DMS DISPLACEMENT MEASUREMENT SYSTEMS

with RS232 OUTPUT

These units are streamlined for PC operation only. Available only in single channel packages. They use RS232 protocol with 5,000 samples/sec maximum data rate. The standard length fiberoptic cable is 914 mm (3 Feet). All units include operational software and Labview™ drivers.

REFLECTANCE DEPENDENT

MODEL	Operating Range	
	mm	mINCH
mDMS-D6	1	40
mDMS-D12	2	80
mDMS-D20	1.25	50
mDMS-D21	2	80
mDMS-D47	5	200
mDMS-D63	3	120
mDMS-D64	6	240
mDMS-D100	10	400
mDMS-D125	15	600
mDMS-D169	19	750
mDMS-D170	30	1200
mDMS-D171	50	2000



Packaged in a 112 x 61 x 33 mm enclosure. Includes Y Cable adaptor for power input and signal output and AC/DC power adaptor.

RC MODELS REFLECTANCE COMPENSATED

MODEL	Operating Range	
	mm	mINCH
mDMS-RC12	0.4	16
mDMS-RC20	1.25	50
mDMS-RC25	0.76	30
mDMS-RC60	3.2	125
mDMS-RC62	2	80
mDMS-RC63	4	160
mDMS-RC90	9	350
mDMS-RC100	5	200
mDMS-RC140	6	250
mDMS-RC171	12.7	500
mDMS-RC190	21	825

MULTI-CHANNEL RACKS FOR Mini-DMS SENSORS

MODEL
10DMS

The model **10DMS** is a 19 inch rack mount enclosure for powering and controlling up to 10 digital sensor channels. Mini-DMS sensors are provided as plug-in modules for easy installation & removal. **10DMS** operates on AC power and is controlled via RS232 communication. Price includes RS232 cable, LabView™ drivers and Philtec DMS Control Software.



10DMS 19" Rack

The rack can be connected with additional racks thereby allowing communication to a larger matrix of sensors.



mcDMS

Sensors are ordered separately.

Specify "mcDMS - model # - options"

and the quantity desired. Prices are the same as the mDMS however they use the prefix mcDMS.

For example, mcDMS-RC100-BT1, qty 8.

Any combination of D and RC models can be mixed in the rack.

Mini-DMS DISPLACEMENT MEASUREMENT SYSTEMS

with USB OUTPUT

These units are designed for PC operation only. Available only in single channel packages. They use USB communication with 5,000 samples/sec maximum data rate. The standard length fiberoptic cable is 914 mm (3 Feet). All units include operational software and Labview™ drivers.

REFLECTANCE DEPENDENT		
MODEL	Operating Range	
	mm	mINCH
muDMS-D6	1	40
muDMS-D12	2	80
muDMS-D20	1.25	50
muDMS-D21	2	80
muDMS-D47	5	200
muDMS-D63	3	120
muDMS-D64	6	240
muDMS-D100	10	400
muDMS-D125	15	600
muDMS-D169	19	750
muDMS-D170	30	1200
muDMS-D171	50	2000



Packaged in a 140 x 82 x 48 mm enclosure. Includes mini-USB to standard USB adapter cable and AC/DC power adaptor.



RC MODELS REFLECTANCE COMPENSATED		
MODEL	Operating Range	
	mm	mINCH
muDMS-RC12	0.4	16
muDMS-RC20	1.25	50
muDMS-RC25	0.76	30
muDMS-RC60	3.2	125
muDMS-RC62	2	80
muDMS-RC63	4	160
muDMS-RC90	9	350
muDMS-RC100	5	200
muDMS-RC140	6	250
muDMS-RC171	12.7	500
muDMS-RC190	21	825

with Optional ANALOG OUTPUTS

Specify **Option A** for analog outputs to be included (this feature is only available with USB sensors).

Example: **muDMS-RC100-A**

In addition to the USB output, muDMS sensors are provided with two analog outputs as shown here.

A1 = Linearized distance output, 4.1 volts FS

A2 = Sensor SNR output, 4.1 volts FS

The analog outputs are active when the sensor is powered up. A PC is required only for the purpose of setting the analog controls.



Digital sensors use a 24 bit ADC. The optional Analog Output uses a 12 bit DAC. Therefore, this Analog Output will have an order of magnitude poorer resolution. In addition, the Analog signal has limited functionality compared to a standard Analog system. The overall speed limit for all is 2 KHz.

OPTIONS FOR DMS SENSORS

FOR D MODELS	FOR RC MODELS	OPTION CODE	FEATURE
√	√	A	PROVIDES ANALOG OUTPUTS FOR muDMS SENSORS
√	√	B	CONNECTORIZES SENSOR SYSTEM WITH IN-LINE CONNECTOR. (D6, RC12 n/a) <i>*OPTION B IS ALSO REQUIRED FOR USE WITH VACUUM PASSTHRU FLANGES & ASSEMBLIES Bv2, Bv3, Bv4, BvF</i>
√	√	B1	CONNECTORIZES SENSOR SYSTEM WITH BULKHEAD CONNECTOR (D6 n/a)
√	√	Bv1	CONNECTORIZES SENSOR SYSTEM WITH SINGLE CHANNEL VACUUM PASSTHRU HARDWARE FOR 1 E-7 TORR (1 nPa). INCLUDES ULTRA-TORR COMPRESSION FITTING (D6, RC12 n/a)
√	√	Bv133	SAME AS Bv1 WITH 1.33" DIAMETER MINI-CF TYPE FLANGE FOR BULKHEAD MOUNTING
√	N/A	Bv2	2 PORT SINGLE CHANNEL VACUUM PASSTHRU FLANGE FOR D MODELS FOR 1 E-11 TORR (10 pPa) (D6 n/a) <i>*Requires Option B</i>
N/A	√	Bv3	3 PORT SINGLE CHANNEL VACUUM PASSTHRU FLANGE FOR RC MODELS FOR 1 E-11 TORR (10 pPa) (RC12 n/a), <i>*Requires Option B</i>
√	N/A	Bv4	4 PORT DUAL CHANNEL VACUUM PASSTHRU FLANGE FOR D MODELS FOR 10 E-11 TORR (D6 n/a) <i>*Requires Option B</i>
√	√	BvF	MULTI-CHANNEL VACUUM PASSTHRU ASSEMBLY FOR 10 E-7 TORR. CAN ACCOMMODATE UP TO 8 D TYPE OR 5 RC TYPE SENSORS. (D6, RC12 & RC20 n/a) <i>*also requires Option B</i>
√	√	C1	INTERLOCKING STAINLESS STEEL SHEATHING FOR FIBEROPTIC CABLES
√	√	C2	SILICONE TUBING SHEATHING FOR FIBEROPTIC CABLES
√	√	C3	SILICONE TUBING OVER PTFE WRAP SHEATHING FOR FIBEROPTIC CABLES
√	√	C4	SILICONE TUBING OVER STEEL MONOCOIL SHEATHING FOR FIBEROPTIC CABLES
√	√	C5	PTFE OVER STAINLESS STEEL INTERLOK SHEATHING FOR FIBEROPTIC CABLES
√	√	C6	PVC OVER NYLON WRAP SHEATHING FOR FIBEROPTIC CABLES
√	√	C7	PTFE TUBING SHEATHING FOR FIBEROPTIC CABLES
√	√	C8	PVC SHRINKWRAP SHEATHING FOR FIBEROPTIC CABLES
√	√	C9	ANNEALED (semi-rigid) STAINLESS STEEL TUBING
√	√	C10	SILICONE OVER SS INTERLOK SHEATHING
√	√	C11	POLYOLEFIN HEAT SHRINK TUBING, MOISTURE/VAPOR BARRIER FOR FIBEROPTIC CABLE
√	√	E	EXTRA LENGTH OF FIBEROPTIC CABLE, 49 FT. MAX. (14.9 m)
√	√	Fv1	LOW VACUUM PASSTHRU FOR 10 E-4 TORR. PROVIDES Ø 0.375" X 3"L SOLID SECTION ON FO CABLE
√	√	Fv2	LOW VACUUM PASSTHRU FOR 10 E-4 TORR. PROVIDES Ø 0.250" X 3"L SOLID SECTION ON FO CABLE
√	√	Fv3	LOW VACUUM PASSTHRU FOR 10 E-4 TORR. PROVIDES Ø 0.500" X 3"L SOLID SECTION ON FO CABLE
√	√	R	AMBIENT LIGHT REJECTION
√	N/A	S	SIDE-VIEWING SENSOR TIP
√	√	T1	CUSTOMIZED SENSOR TIP, STRAIGHT
√	√	T2	CUSTOMIZED SENSOR TIP, STRAIGHT and THREADED
√	√	T3	CUSTOMIZED SENSOR TIP, NON-METALLIC
√	√	T4	SIMPLE RIGHT ANGLE TIP
√	√	T5	SQUARE BODY RIGHT ANGLE TIP, UNTHREADED
√	√	T6	SQUARE BODY RIGHT ANGLE TIP, THREADED
√	√	T7	SPECIAL TIP MADE TO CUSTOMER SPECIFICATIONS
√	√	T8	HIGH TEMPERATURE TIP, 250°C MAX.
√	√	T9	HIGH TEMPERATURE TIP, 482°C MAX.
√	√	T10	CUSTOMIZED SENSOR TIP, METALLIC BUT NON-MAGNETIC
√	√	T11	INVAR PROBE TIP FOR LOW EXPANSION COEFFICIENT
√	√	W	WINDOW PROBE FOR HIGH PRESSURE OR VACUUM
√	√	Wb	SAPPHIRE WINDOW BRAZED TO SENSOR TIP FOR HIGH PRESSURE OR VACUUM

REPLACEABLE SENSOR TIPS

MODEL NUMBER FORMAT:

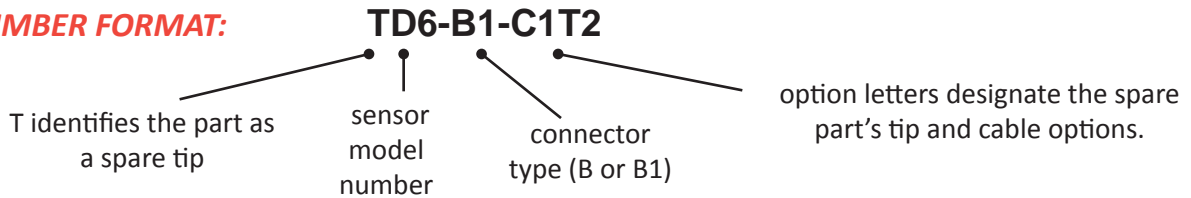

CONNECTORIZED FIBEROPTICS

Sensors are available with in-line (Option B) or bulkhead mounted (Option B1) connectors. Options B and B1 offer several advantages such as:

- Easy replacement of damaged tips
- Substitution of alternate tips
- Removal of electronics from machinery without removing sensor tips

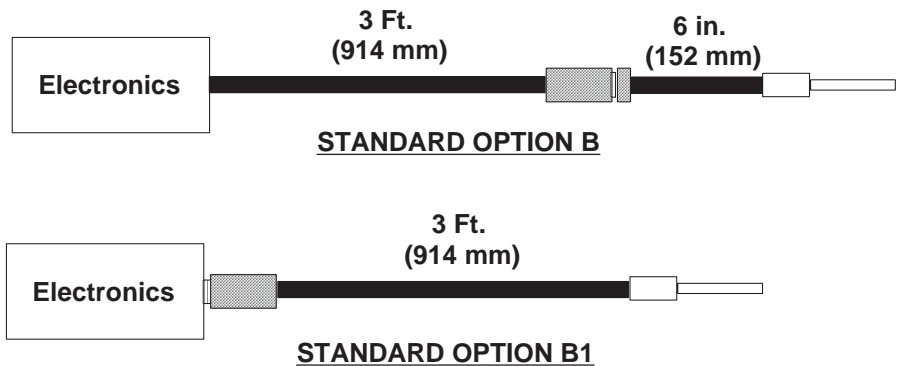
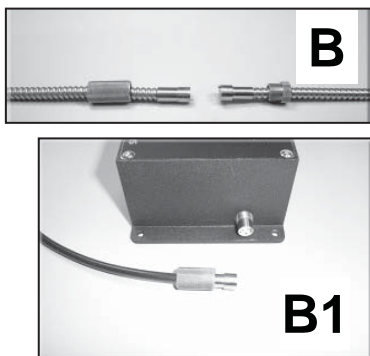

SPARE TIP NOTES

Different model tips and electronics can not be mixed.

A model D100 tip can only be used with a model D100 sensor package; a model RC100 tip can only be used with a model RC100 sensor package; etc.

Noise Increases. Custom tips can be provided using any combination of tip, sheathing and length options. However, there are tradeoffs to consider due to light losses at the connector interface. We do not recommend more than one connector interface per sensor. Connectorized sensors may have increased noise levels (2 - 3 times higher). Use of connectorized fiberoptics with very dark targets is not recommended.

D MODELS REFLECTANCE DEPENDENT	
MODEL	B or B1
TD6	not available
TD12 - TD47	B or B1
TD63 - TD100	B or B1
TD125 - TD170	B or B1
TD171	B or B1

RC MODELS REFLECTANCE COMPENSATED	
MODEL	B or B1
TRC12	not available
TRC20, TRC60	B or B1
TRC25, TRC62, TRC63	B or B1
TRC100, TRC171	B or B1
TRC90, TRC140, TRC190	B or B1

VACUUM PASSTHRU HARDWARE

Vacuum passthru hardware is available in a variety of packages from low to ultra-high vacuum, and for single and multi-channel applications.

MODEL or Option	SENSOR CHANNELS	SENSOR TYPE	TORR RATING	IMAGE
Bv1	Single / Dual	D or RC	10 ⁻⁷	
Bv133	Single / Dual	D or RC	10 ⁻⁷	
Bv2	Single	D	10 ⁻¹¹	
Bv3	Single	RC	10 ⁻¹¹	
Bv4	Dual	D	10 ⁻¹¹	
BvF - CF	Multi	D and RC	10 ⁻⁷	
BvF - ISO	Multi	D and RC	10 ⁻⁷	
Fv1	Single	D or RC	10 ⁻⁴	
Fv2	Single	D or RC	10 ⁻⁴	
Fv3	Single	D or RC	10 ⁻⁴	
W	Single	D or RC	10 ⁻⁷	
W _b	Single	D or RC	10 ⁻¹¹	

ACCESSORIES & SERVICES

SENSOR CALIBRATIONS

Sensors in the field can be returned to the factory for a gap calibration in air.
Sensors can also be calibrated while submerged in a fluid sample provided by the customer.

- **SENSORCALIBRATIONSINAIR**..... **cal-A**
- **SENSORCALIBRATIONSINFLUID**..... **cal-F**
- **NIST TRACEABLE CALIBRATIONS available on request**

CALIBRATION CHECK MIRROR

A calibration check mirror is provided along with a Certificate of Calibration which specifies the accuracy of a single point sensor reading.

..... **Model CM32940, Ø5 x 2 mm**

COMPRESSION FITTINGS

Stainless Steel fittings with nylon compression ferrules can be used to hold sensor tips and vacuum passthru fittings. Overall length is approx. 1.4". They can be bulkhead mounted into a 0.5" deep straight threaded hole.

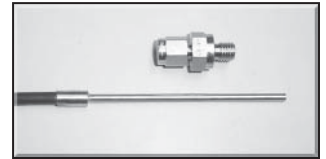

- for D63, D64, D100, RC100. Requires 5/16-24 threaded hole **Model CF125**
- for D169 - D171, RC171. Requires 3/8-24 threaded hole **Model CF187**
- for Fv2. Requires 7/16-20 threaded hole **Model CF250**
- for RC89, RC90, RC140, RC190. Requires 1/2-20 threaded hole **Model CF312**
- for Fv1, Requires 9/16-18 threaded hole **Model CF375**
- for Fv3, Requires 3/4-16 threaded hole **Model CF500**

MIRRORED TARGET DISCS

Type 316 stainless steel .032" thick with #8 mirror polish. When bonded to a target, these specimens present a smooth mirrored surface to optimize sensor performance.

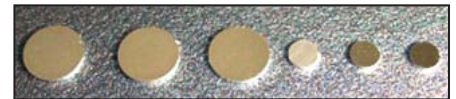

- Ø 6.35 mm (1/4") Disc **Model M25**
- Ø 12.7 mm (1/2") Disc **Model M50**

RETRO-REFLECTIVE TAPE

Model RT1, 100 mm square



PROBE MOUNTING BLOCKS

Aluminum block for use with probes having a Ø 1/4" or Ø 3/16" collars. The block can be mounted on a linear stage to provide a fine active adjustment of the sensor-to-target gap.



- for any model with Ø 1/4" collared probes **Model B25**
- for any model with Ø 5/16" collared probes **Model B31**

MICRO-STAGES

These manual linear stages provide a fine adjustment (80 TPI).



- Single Axis Stage, 0.18" Travel for use with Model B25 Block **Model 56416**
- Single Axis Stage, 0.50" Travel for use with Model B31 Block **Model 56422**

ACCESSORIES & SERVICES

mini-DMS Y-CABLE POWER ADAPTORS

Model PS-1 is required for operation of any mini-DMS sensor. Includes AC/DC power supply and Y adaptor cable with D-sub female 9 pin (standard RS-232 connector) and 2.1 mm coax male power connector.



PS-1

Model PS-10 enables single channel operation of any rack mountable mcDMS sensor (without using the 10DMS rack). Includes AC/DC power supply and Y adaptor cable with D-sub female 9 pin (standard RS-232 connector) and 2.1 mm coax male power connector.

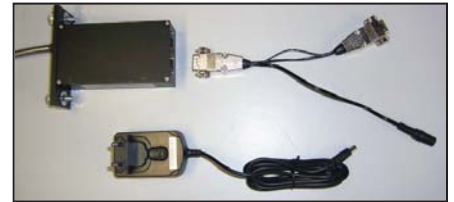

PS-10

Model PS-U universal power supply for mini-DMS sensors (power supply only)

Option Q POWER SUPPLY

Model PS-Q provides a 12 VDC, 500 ma AC/DC power supply terminated with Philtec's 3 Pin Weathertight Option Q Connector.



PS-Q

USB To SERIAL RS-232 ADAPTOR CABLE

Model ADB9 is a 500 Kbps High Speed Adaptor with 6 inch long cable, 9-pin Serial Male to USB Type A Male, USB 1.1 Compliant, Works with USB 1.1 & 2.0 ports. Requires Windows 98 SE, ME, 2000, XP, Vista, Windows 7



ADB9

mini "B" to "A" USB Locking Connector

model AUSB is a 2 cm long, robust dust and waterproof connection, fully shielded providing good levels of noise immunity and EMI protection. For use with muDMS sensors.



AUSB

