

Fiberoptic Sensor - Reflectance Compensated*

Model RC60

Fiberoptic Cable & Sensor Tip - Actual Size



For The Measurement of Distance, Displacement and Vibration

Features

- Reflectance Compensated Output
- 1.5 mm Diameter Spot Size (0.060 inch)
- 3.2 mm Operating Range (0.125 inch)
- 1 mm Linear Range (0.040 inch)
- 2.4 mv/ μ m Sensitivity (60 mv/mil)

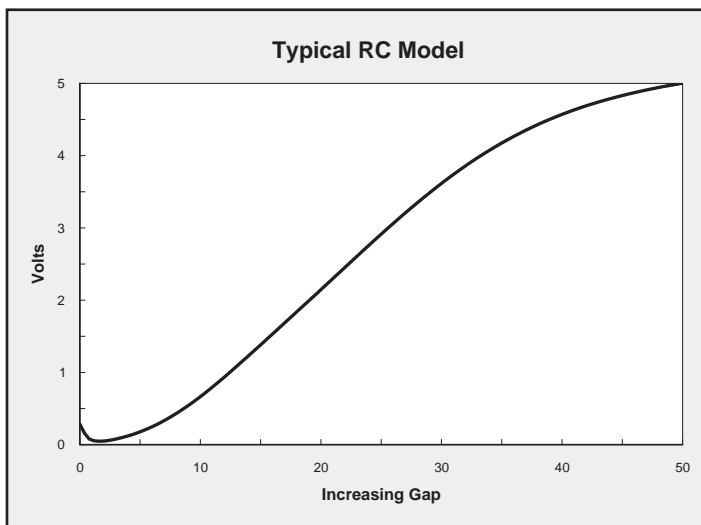

Tip & Cable Dimensions

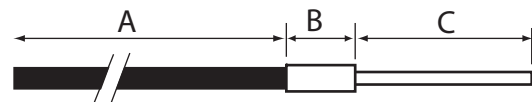

FEATURE	mm	inch
Tip Outer Diameter, Ø C	1.83	0.072
Fiberoptic Diameter	1.52	0.060
Tip Length, C	38.1	1.5
Collar Length, B	12.7	0.5
Collar Diameter, Ø B	6.35	0.250
Cable Length, A	915	36
Cable Diameter, Ø A	5.2	0.205
Cable Min. Bend Radius	12.7	0.5

*These are reflective type transducers based upon detecting the intensity of reflected light. RC Model sensors have a pair of adjacent fiberoptic detectors in the sensor tip. Light reflected off the target follows two separate paths back to the electronics where a ratiometric calculation provides the distance measurement which is independent of varying surface reflectance; i.e., *reflectance compensated*.

PHILTEC

www.philtec.com

Precision Dynamic Measurements



Two Instrument Outputs To Choose From

This sensor can be provided as an analog or as a digital instrument.

- RC60 ... Analog
- DMS-RC60 ... standard DMS
- mDMS-RC60 ... miniDMS with RS232 out
- muDMS-RC60 ... miniDMS with USB out



Analog sensors are fast responding units ideal for process control and relative motion measurements in dynamic applications:

- DC-20 KHz is standard
- DC-200 KHz or higher is optional
- DC-100 Hz provides best resolution

Standard analog units include:

- Electronics with 0 to +5 VDC output
- 3 foot long fiberoptic cable

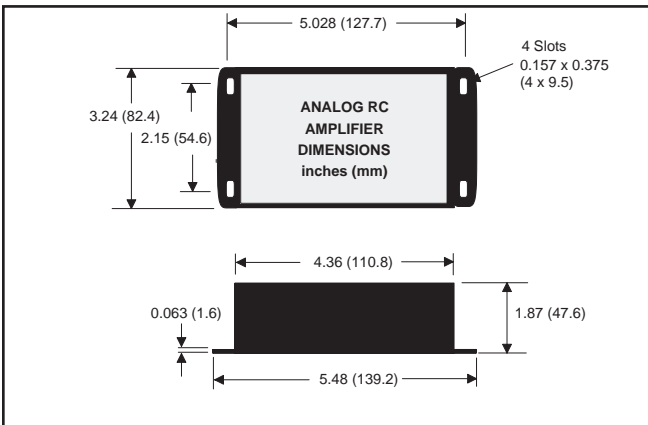

ANALOG OUTPUT

A calibration chart is provided with each sensor tip giving the voltage output response to distance. There are three ways to derive accurate distance measurements:

- within the bounds of the linear range, multiply sensitivity by the change in voltage output
- create a lookup table using the XY calibration data points
- use a polynomial curve fit to accurately map the sensor's output function

SENSOR TIP ALIGNMENT

RC sensors have adjacent fiber bundles in the face of the sensor. An alignment flat is provided on the casing to aid with alignment. The flat is ground parallel to the split between the adjacent fiberoptic bundles, and located on the light transmitting side.



Displacement Measurement Systems (DMS) are the best choice for absolute distance measurements, multiplexing and process control applications, with data rates up to 5,000 readings/second. They provide linearized distance output and on board calibration storage capacity for 25 calibrations. Three types are available, each equipped with temperature stabilized electronics:

1. Standard DMS units include:

- Electronics with RS-232 communication
- Keypad/LCD for local operation

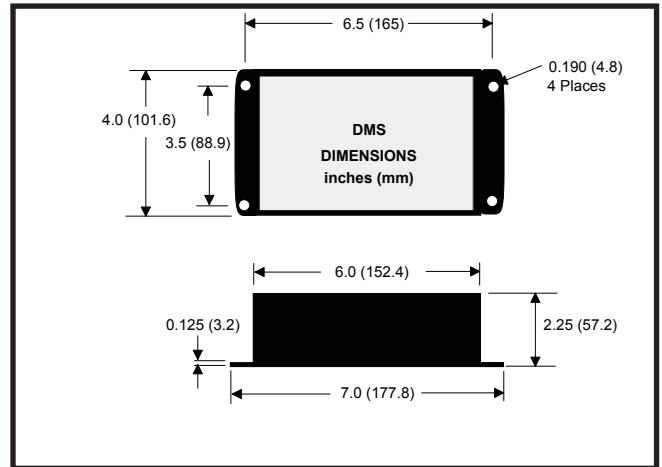

2. Mini-DMS units are full-featured for PC operation via RS232 communication, they are not equipped with keypad/display.

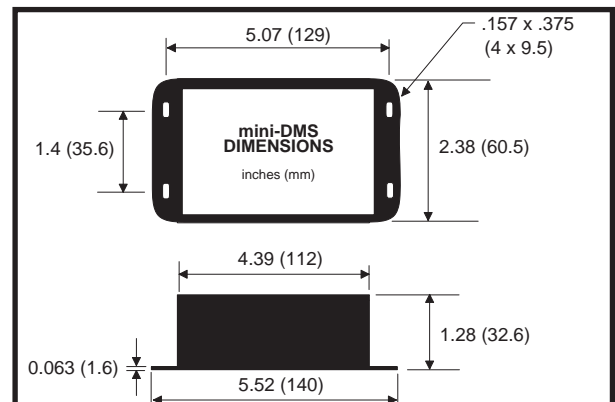

3. muDMS units are full-featured for PC operation via USB communication, they are not equipped with keypad/display. They are supplied in the RC analog sensor enclosure shown above left.

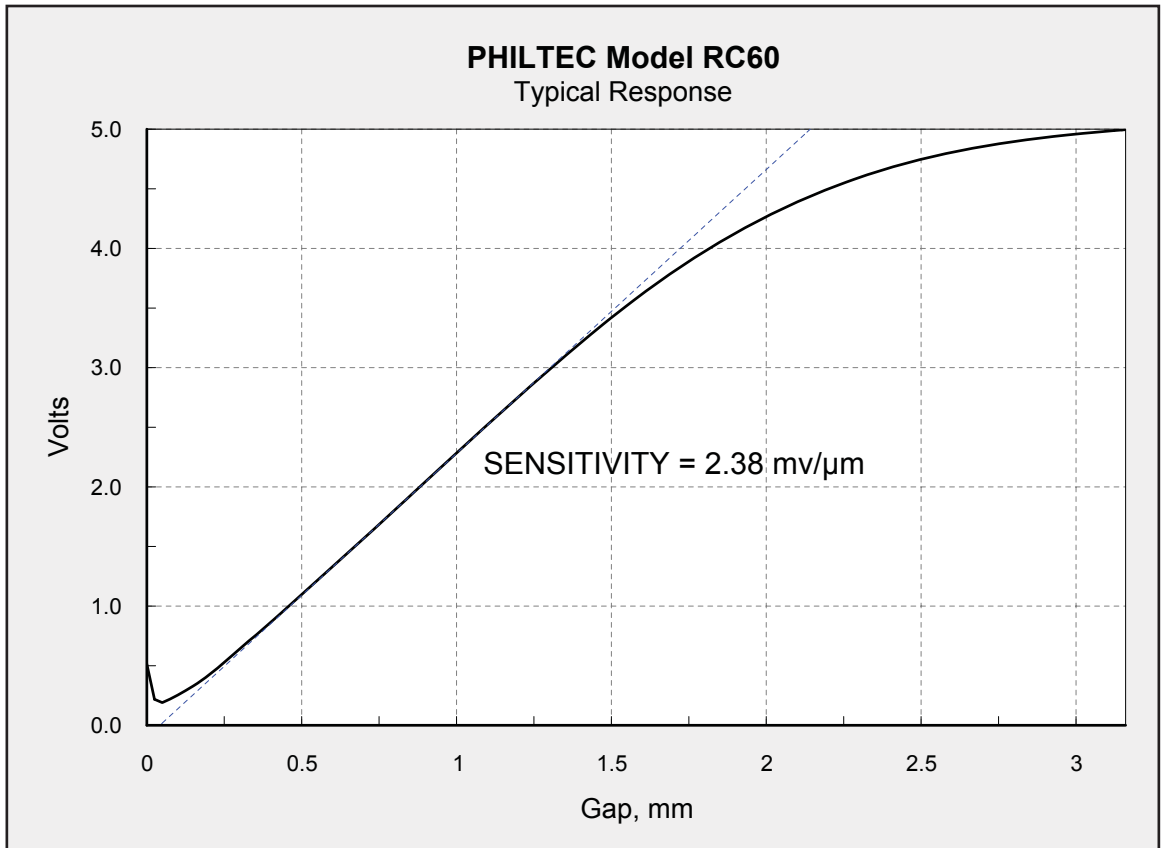

Conversions: 1 micron = 39.37 microinch 1 mm = 39.37 mils 1 mil = 0.001 inch = 25.4 microns = 0.0254 mm

Standard Specifications - RC60									
Electronics			Fiberoptics		Outputs				
	Analog	DMS	Light Beam spread	66°	Analog Voltage			DMS RS232	
Light Source	LED, 880 nm		Cable Sheathing	PVC over Steel Monocoil	Total Range	0.125 in.	3.18 mm	Total Range	3.18 mm
Input Voltage	+12 to +24 VDC	+12 VDC	Tip Material	300 Series SS	Linear Range	38 mils	1 mm	Distance	23 bit resolution
Input Current	125 ma max	500 ma max	Tip Epoxy Outgas	0.3% @ 200°C 2.4% @ 300°C	Nominal Standoff	56 mils	1.4 mm	Reflectance	8 bit resolution
Bandwidth	DC-20 KHz 3 db down	5 KHz max	Tip Operating Pressure	35 bar	Nominal Sensitivity	56 mv/mil	2.2 mv/μm	Amplifier Temperature	12 bit resolution
Isothermal Drift	0.5%	0.05%	Tip Operating Temperature	-55 to 175°C continuous; to 350°C intermittent 1-2 hours	Resolution*	DC - 200KHz 110 μin	2.8 μm	Resolution* Pk-Pk Units at Mid Range using 50% Signal Power	ADC AVG = 2 pk-pk = 0.2 μm ADC AVG = 16 pk-pk = 0.1 μm ADC AVG = 256 pk-pk = 40 nm ADC AVG = 4096 pk-pk = 10 nm

*These specifications represent best case performance where: the target is flat, smooth and highly reflective, the sensor is perpendicular to the target, the sensor is gapped to its range of highest sensitivity, fiberoptic cable lengths are standard and the cables are not connectorized.

Custom Hardware To Customer Specifications



PHILTEC, INC., ANNAPOLIS, MD USA 410-757-4404
800-453-6242 e-mail sensors@philterec.com