

Fiberoptic Sensor - Reflectance Compensated*

Model RC140



For The Measurement of Distance, Displacement and Vibration

Features

- Reflectance Compensated Output
- Designed for Large Standoff
- 10 mm Total Range (0.40 inch)
- 1.4 mv/ μm Sensitivity (35 mv/mil)
- 7.5 mm Standoff Distance

Tip & Cable Dimensions

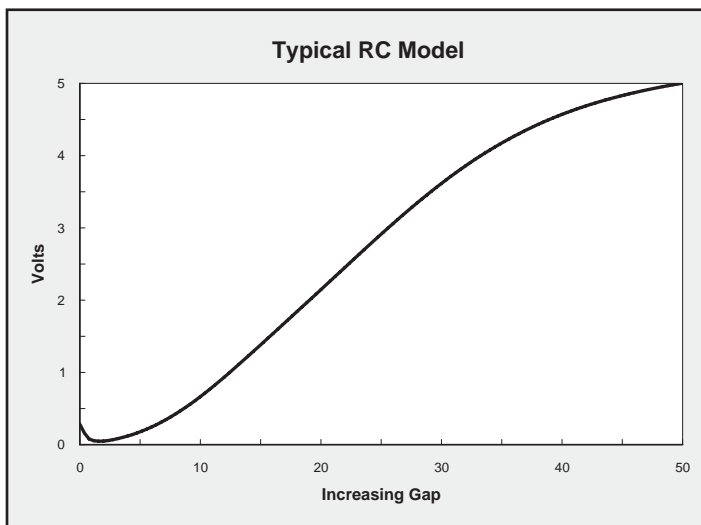
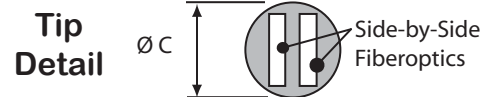

FEATURE	mm	inch
Tip Outer Diameter, \varnothing B	7.925	0.312
Fiberoptic Area	3.73 x 4.75	0.147 x 0.187
Tip Length, B	38.1	1.5
Cable Length, A	915	36
Cable Diameter, \varnothing A	5.97	0.235
Cable Min. Bend Radius	25.4	1

*These are reflective type transducers based upon detecting the intensity of reflected light. RC Model sensors have a pair of adjacent fiberoptic detectors in the sensor tip. Light reflected off the target follows two separate paths back to the electronics where a ratiometric calculation provides the distance measurement which is independent of varying surface reflectance; i.e., *reflectance compensated*.

PHILTEC

www.philtec.com

Precision Dynamic Measurements



Two Instrument Packages To Choose From

This sensor can be provided as an analog or as a digital instrument. For available options and how to order go to www.philtec.com



Analog sensors are fast responding units ideal for relative motion measurements in dynamic applications:

- DC-20 KHz is standard
- DC-200 KHz or higher is optional
- DC-100 Hz provides best resolution

Standard analog units include:

- Electronics with 0 to +5 VDC output
- 3 foot long fiberoptic cable

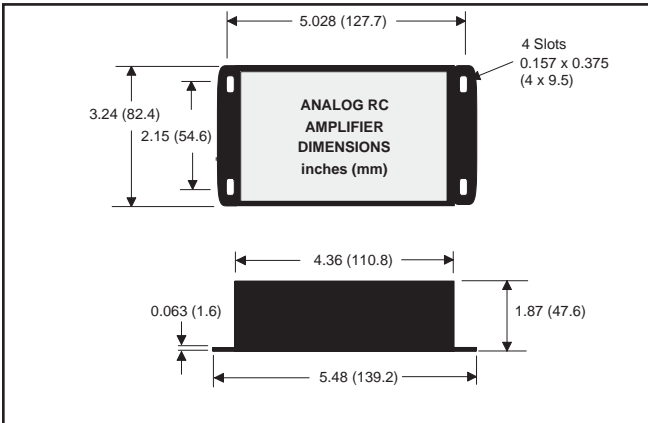

ANALOG OUTPUT

A calibration chart is provided with each sensor tip giving the voltage output response to distance. There are three ways to derive accurate distance measurements:

- within the bounds of the linear range, multiply sensitivity by the change in voltage output
- create a lookup table using the XY calibration data points
- use a polynomial curve fit to accurately map the sensor's output function

SENSOR TIP ALIGNMENT

RC sensors have adjacent fiber bundles in the face of the sensor. An alignment flat is provided on the casing to aid with alignment. The flat is ground parallel to the split between the adjacent fiberoptic bundles, and located on the light transmitting side.



Displacement Measurement Systems (DMS) are the best choice for absolute distance measurements, multiplexing and process control applications, with data rates up to 5,000 readings/second. Two sizes are available:

Standard DMS units include:

- Electronics with RS-232 communication
- Keypad/LCD for local operation

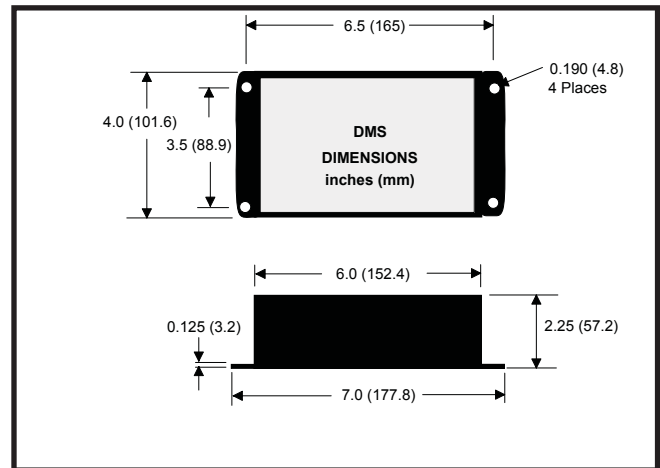

Mini-DMS units are full-featured for PC operation only, they are not equipped with keypad/display.

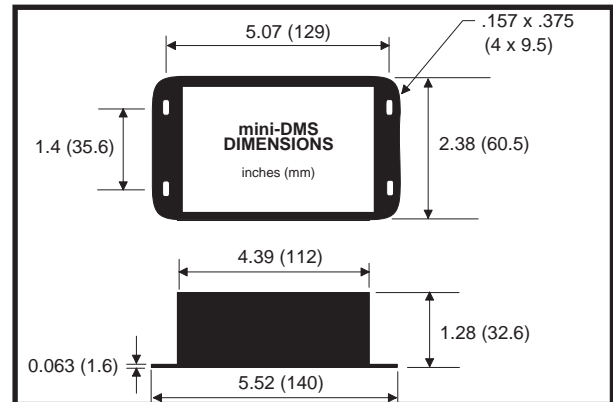

DIGITAL OUTPUT

DMS units provide distance output via RS232. Gap calibration data is stored on board DMS units. They provide accurate distance measurements over the sensor's entire operating range using a 24 bit internal lookup table. They have storage capacity for many additional calibrations.

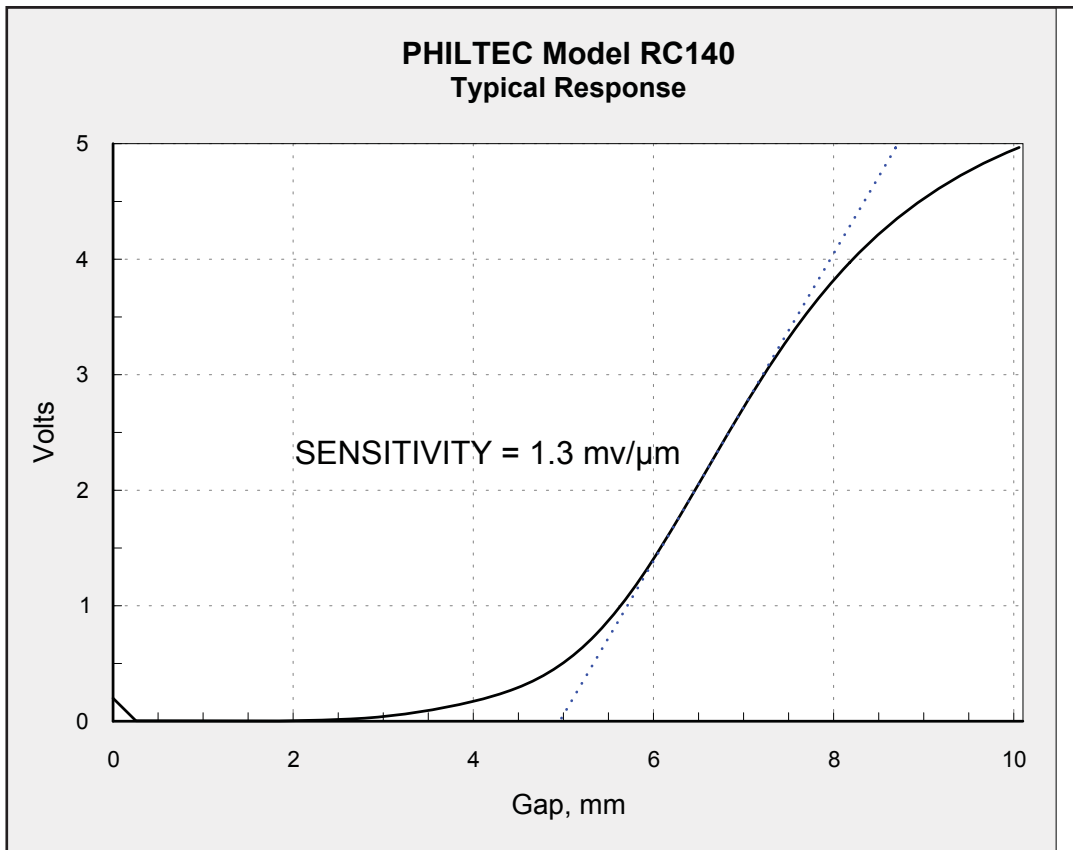

Conversions: 1 micron = 39.37 microinch 1 mm = 39.37 mils 1 mil = 0.001 inch = 25.4 microns = 0.0254 mm

Standard Specifications - RC140									
Electronics			Fiberoptics		Outputs				
	Analog	DMS	Light Beam spread	30°	Analog Voltage			DMS RS232	
Light Source	LED, 880 nm		Cable Sheathing	PVC over Steel Monocoil	Total Range	0.40 in.	10 mm	Total Range	10 mm
Input Voltage	+12 to +24 VDC	+12 VDC	Tip Material	300 Series SS	Linear Range	65 mils	1.7 mm	Distance	23 bit resolution
Input Current	125 ma max	500 ma max	Tip Epoxy Outgas	0.3% @ 200°C 2.4% @ 300°C	Nominal Standoff	295 mils	7.5 mm	Reflectance	8 bit resolution
Band-width	DC-20 KHz 3 db down	5 KHz max	Tip Operating Pressure	35 bar	Nominal Sensitivity	30 mv/mil	1.2 mv/μm	Amplifier Temperature	12 bit resolution
Iso-thermal Drift	0.5%	0.05%	Tip Operating Temperature	-55 to 175°C continuous; to 350°C intermittent 1-2 hours	<u>Resolution*</u> DC - 200KHz DC - 20 KHz DC - 100 Hz	280 μin 140 μin 35 μin	7.1 μm 3.6 μm 0.9 μm	<u>Resolution*</u> Pk-Pk Units at Mid Range using 50% Signal Power	ADC AVG = 2 pk-pk = 0.5 μm ADC AVG = 16 pk-pk = 0.25 μm ADC AVG = 256 pk-pk = 0.1 μm ADC AVG = 4096 pk-pk = 0.05 μm

*These specifications represent best case performance where: the target is flat, smooth and highly reflective, the sensor is perpendicular to the target, the sensor is gapped to its range of highest sensitivity, fiberoptic cable lengths are standard and the cables are not connectorized.

Custom Hardware To Customer Specifications



PHILTEC, INC., ANNAPOLIS, MD USA 410-757-4404
800-453-6242 e-mail sensors@philterec.com