

Fiberoptic Sensor - Reflectance Dependent\*

# Model D125

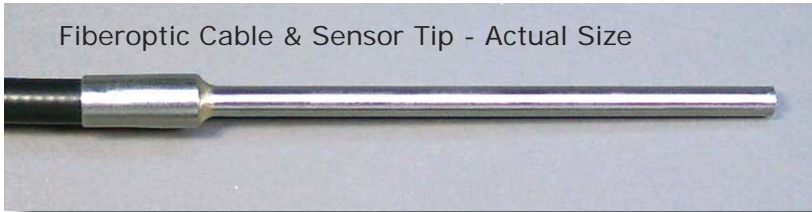

For The Measurement of Distance, Displacement and Vibration

**Features**

- Reflectance Dependent Output with Dual Functions Far Side/Near Side
- Ø 3.18 mm Target Spot Size (0.125 inch)
- 15 mm Total Operating Range (0.600 inch)
- 0.65 mv/µm Far Side Sensitivity (17 mv/mil)
- 40 mv/µm Near Side Sensitivity (1000 mv/mil)

**Tip & Cable Dimensions**

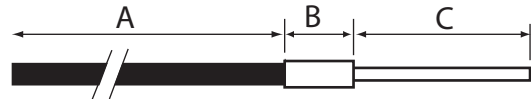

FEATURE	mm	inch
Tip Outer Diameter, Ø C	3.96	0.156
Fiberoptic Diameter	3.18	0.125
Tip Length, C	76.2	3
Collar Length, B	12.7	0.5
Collar Diameter, Ø B	7.11	0.280
Cable Length, A	914	36
Cable Diameter, Ø A	5.89	0.232
Cable Min. Bend Radius	25.4	1

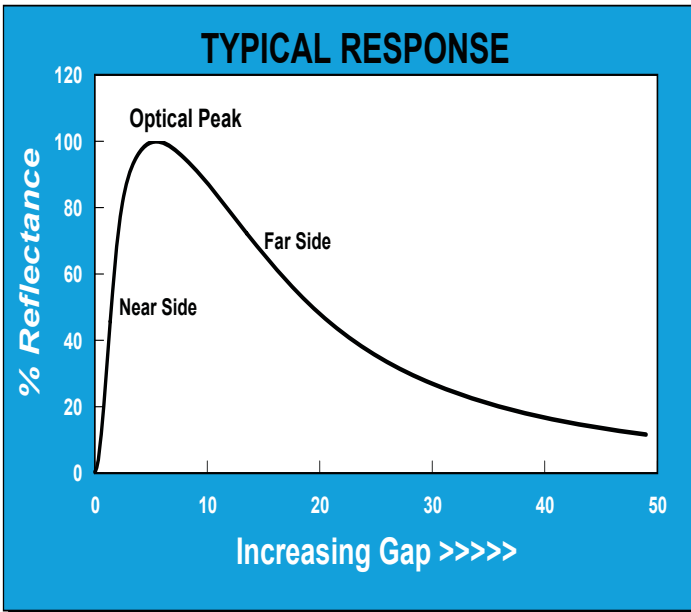

\*These are reflective type transducers based upon detecting the intensity of reflected light. With D Model sensors, the output signal is proportional to: a) the gap distance from the sensor tip-to-target; and, b) the reflectivity of the target surface. D models are commonly used in applications where the target reflectivity stays constant, i.e., the target has a reciprocating or vibratory motion parallel to the axis of the sensor.



## Two Instrument Outputs To Choose From

This sensor can be provided as an analog or as a digital instrument. For available options and how to order go to [www.philtec.com](http://www.philtec.com)



**A**nalog sensors are fast responding units ideal for relative motion measurements in dynamic applications:

- DC-20 KHz is standard
- DC-200 KHz or higher is optional
- DC-100 Hz provides best resolution

Standard analog units include:

- Electronics with 0 to +5 VDC output
- 3 foot long fiberoptic cable

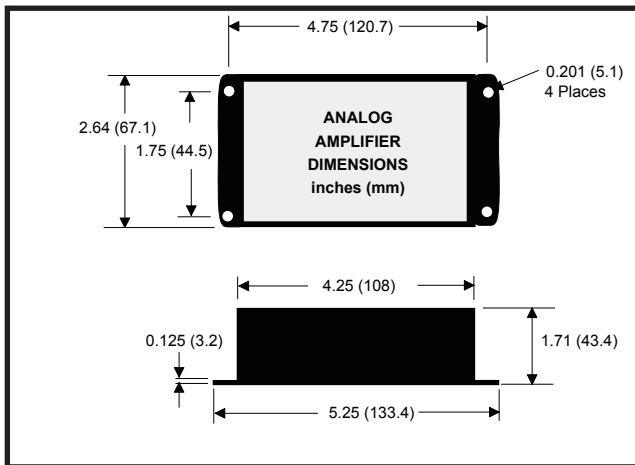

### ANALOG OUTPUT

Calibration charts are provided with each sensor tip giving the near and far side voltage output responses to distance. There are three ways to derive accurate distance measurements:

- within the bounds of the linear range, multiply sensitivity by the change in voltage output
- create a lookup table using the XY calibration data points
- use a polynomial curve fit to accurately map the sensor's output function

The effect of changing target reflectance is to shift the voltage output higher or lower. A gain control is provided for calibration of the sensor output to various target surfaces. In-situ calibration is performed simply, by adjusting the sensor's tip-to-target gap until the peak output is attained, and then by using the gain control to set the peak voltage reading to full scale. This allows the sensor to be used to perform precision linear motion measurements on most materials.

**D**isplacement Measurement Systems (DMS) are the best choice for absolute distance measurements, multiplexing and process control applications, with data rates up to 5,000 readings/second. Two sizes are available:

**Standard DMS** units include:

- Electronics with RS-232 communication
- Keypad/LCD for local operation

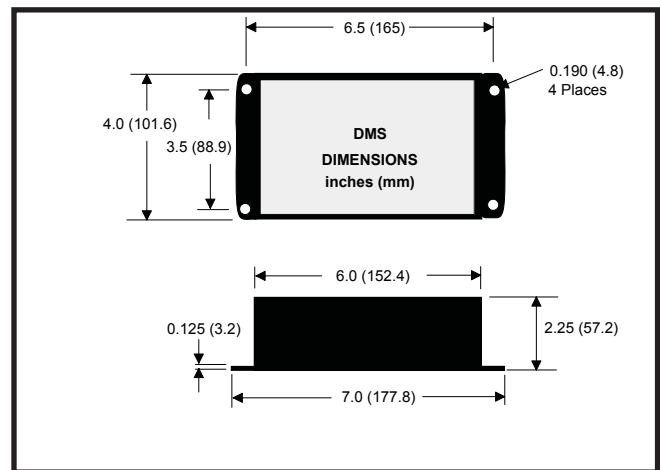

**Mini-DMS** units are full-featured for PC operation only, they are not equipped with keypad/display.

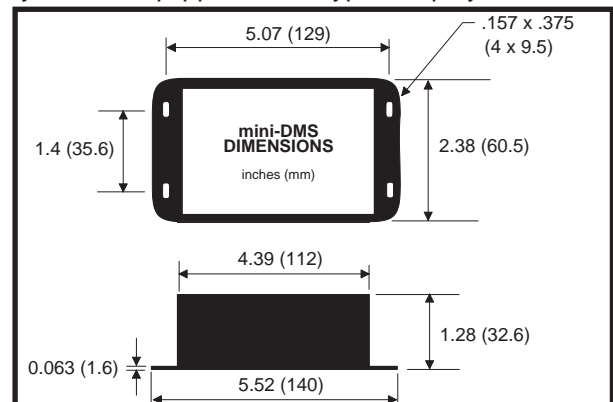

### DIGITAL OUTPUT

DMS units provide distance output via RS232. Gap calibration data is stored on board DMS units. They provide accurate distance measurements over the sensor's entire operating range using a 24 bit internal lookup table. They have storage capacity for many additional calibrations.

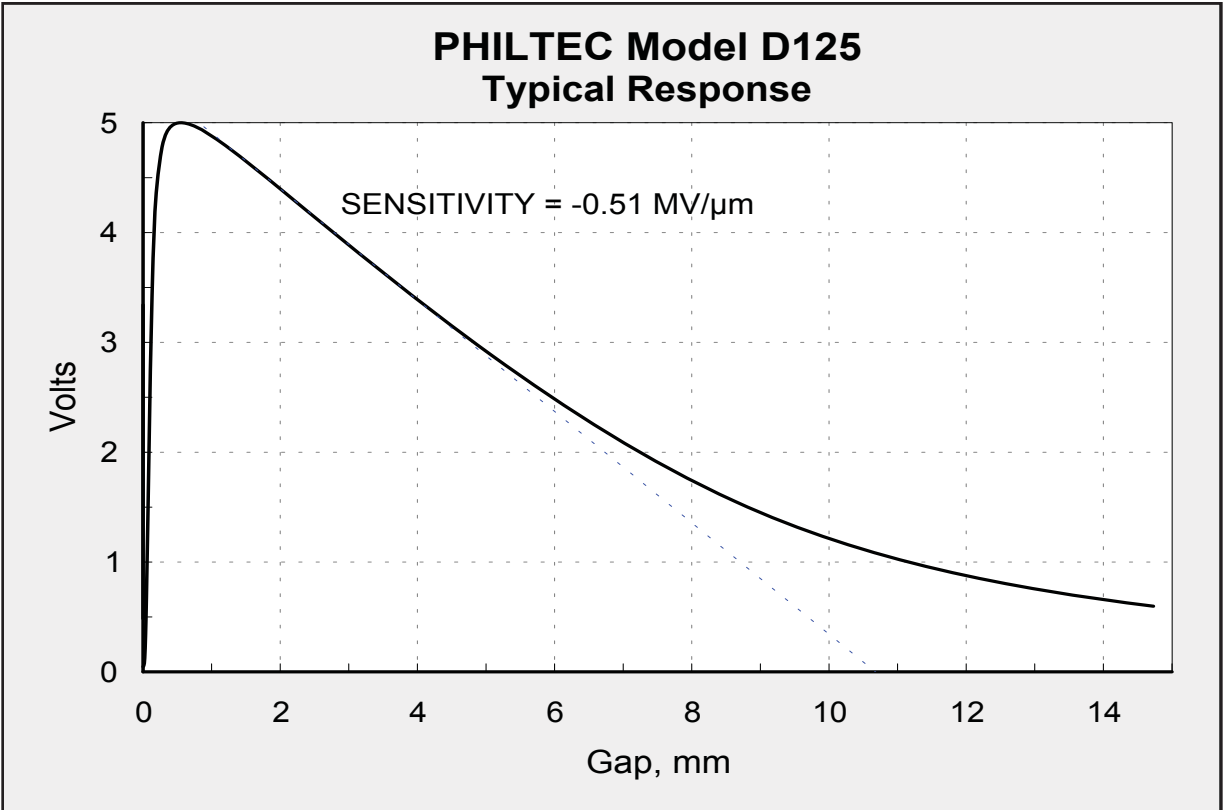

Conversions: 1 micron = 39.37 microinch 1 mm = 39.37 mils 1 mil = 0.001 inch = 25.4 microns = 0.0254 mm

Standard Specifications - D125 Far Side									
Electronics			Fiberoptics		Outputs				
	Analog	DMS	Light Beam spread	30°	Analog Voltage			DMS RS232	
Light Source	LED, 880 nm		Cable Sheathing	PVC over Steel Monocoil	Total Range	0.600 in.	15 mm	Total Range	15 mm
Input Voltage	+12 to +24 VDC	+12 VDC	Tip Material	300 Series SS	Linear Range	115 mils	2.9 mm	Distance	23 bit resolution
Input Current	125 ma max	500 ma max	Tip Epoxy Outgas	0.3% @ 200°C 2.4% @ 300°C	Nominal Standoff	85 mils	2.1 mm	Reflectance	8 bit resolution
Bandwidth	DC-20 KHz 3 db down	5 KHz max	Tip Operating Pressure	35 bar	Nominal Sensitivity	16 mv/mil	0.6 mv/μm	Amplifier Temperature	12 bit resolution
Iso-thermal Drift	0.5%	0.05%	Tip Operating Temperature	-55 to 175°C continuous; to 350°C intermittent 1-2 hours	<u>Resolution*</u> DC - 200KHz DC - 20 KHz DC - 100 Hz	60 μin 45 μin 10 μin	1.5 μm 1.1 μm 0.25 μm	<u>Resolution*</u> Pk-Pk Units at Mid Range using 50% Signal Power	ADC AVG = 2 pk-pk = 250 nm ADC AVG = 16 pk-pk = 130 nm ADC AVG = 256 pk-pk = 30 nm ADC AVG = 4096 pk-pk = 10 nm

\*These specifications represent best case performance where: the target is flat, smooth and highly reflective, the sensor is perpendicular to the target, the sensor is gapped to its range of highest sensitivity, fiberoptic cable lengths are standard and the cables are not connectorized.

### Custom Hardware To Customer Specifications

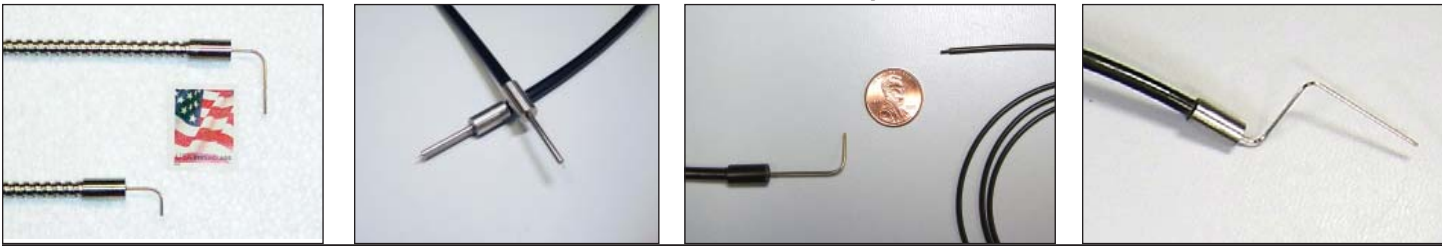

**PHILTEC, INC., ANNAPOLIS, MD USA 410-757-4404**  
**800-453-6242 e-mail sensors@philterec.com**

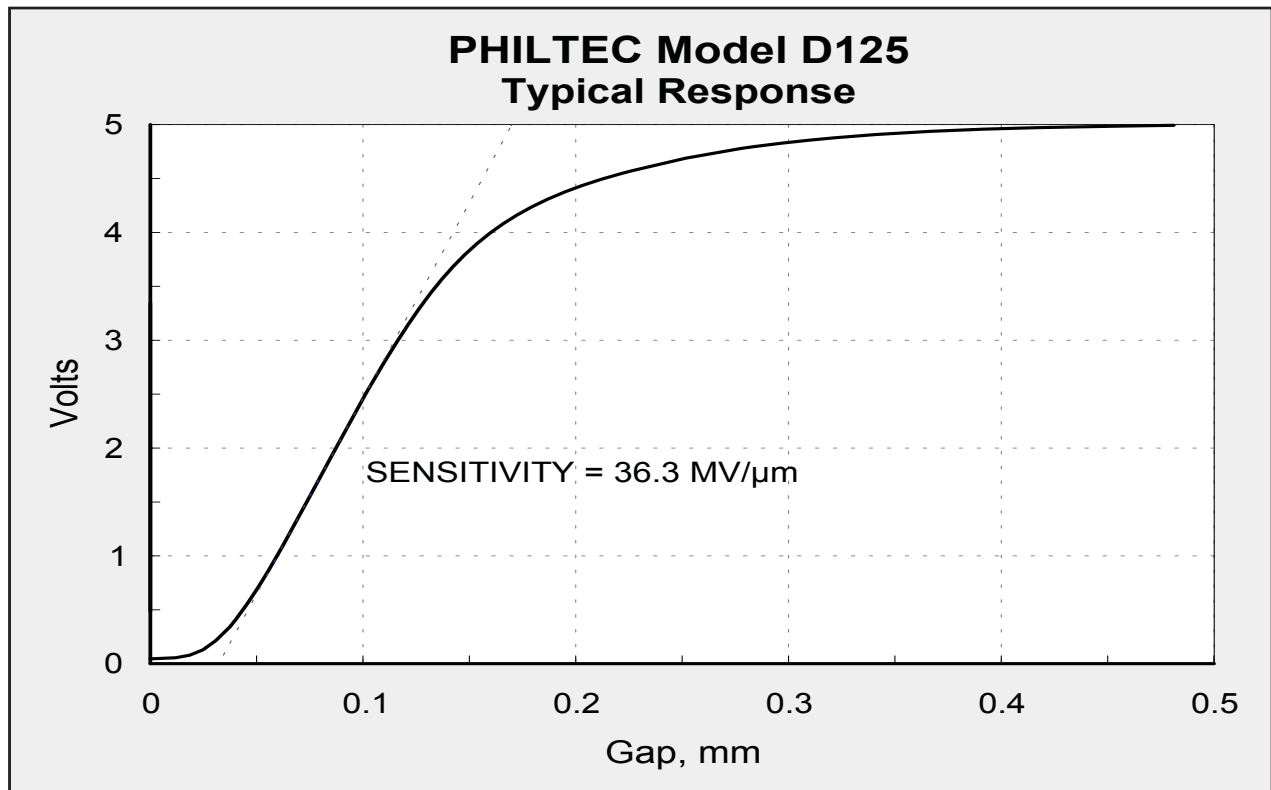

Conversions: 1 micron = 39.37 microinch 1 mm = 39.37 mils 1 mil = 0.001 inch = 25.4 microns = 0.0254 mm

Standard Specifications - D125 Near Side										
Electronics			Fiberoptics		Outputs					
	Analog	DMS	Light Beam spread	30°	Analog Voltage			DMS RS232		
Light Source	LED, 880 nm		Cable Sheathing	PVC over Steel Monocoil	Total Range	19 mils	480 μm	Total Range	480 μm	
Input Voltage	+12 to +24 VDC	+12 VDC	Tip Material	300 Series SS	Linear Range	2 mils.	51 μm	Distance	23 bit resolution	
Input Current	125 ma max	500 ma max	Tip Epoxy Outgas	0.3% @ 200°C 2.4% @ 300°C	Nominal Standoff	3 mils	76 μm	Reflectance	8 bit resolution	
Bandwidth	DC-20 KHz 3 db down	5 KHz max	Tip Operating Pressure	35 bar	Nominal Sensitivity	1000 mv/mil	40 mv/μm	Amplifier Temperature	12 bit resolution	
Iso-thermal Drift	0.5%	0.05%	Tip Operating Temperature	-55 to 175°C continuous; to 350°C intermittent 1-2 hours	Resolution*	DC - 200KHz DC - 20 KHz DC - 100 Hz	1.5 μin 0.75 μin 0.25 μin	40 nm 20 nm 6 nm	Resolution* Pk-Pk Units at Mid Range using 50% Signal Power	ADC AVG = 2 pk-pk = 50 nm ADC AVG = 16 pk-pk = 40 nm ADC AVG = 256 pk-pk = 10 nm ADC AVG = 4096 pk-pk = 3 nm

\*These specifications represent best case performance where: the target is flat, smooth and highly reflective, the sensor is perpendicular to the target, the sensor is gapped to its range of highest sensitivity, fiberoptic cable lengths are standard and the cables are not connectorized.

**Many Options are Available Including Replaceable Tips, Vacuum Passthrus and Non-Metallic Tips**



**PHILTEC, INC., ANNAPOLIS, MD USA 410-757-4404**  
**800-453-6242 e-mail sensors@philtec.com**