

Fiberoptic Sensor - Reflectance Dependent*

Model D12

Fiberoptic Cable & Sensor Tip - Actual Size



For The Measurement of Distance, Displacement and Vibration

Features

- Reflectance Dependent Output with Dual Functions Far Side/Near Side
- \varnothing 310 Micron Target Spot Size (0.012 inch)
- 2 mm Total Operating Range (0.080 inch)
- 5 mv/ μ m Far Side Sensitivity (125 mv/mil)
- 40 mv/ μ m Near Side Sensitivity (1000 mv/mil)

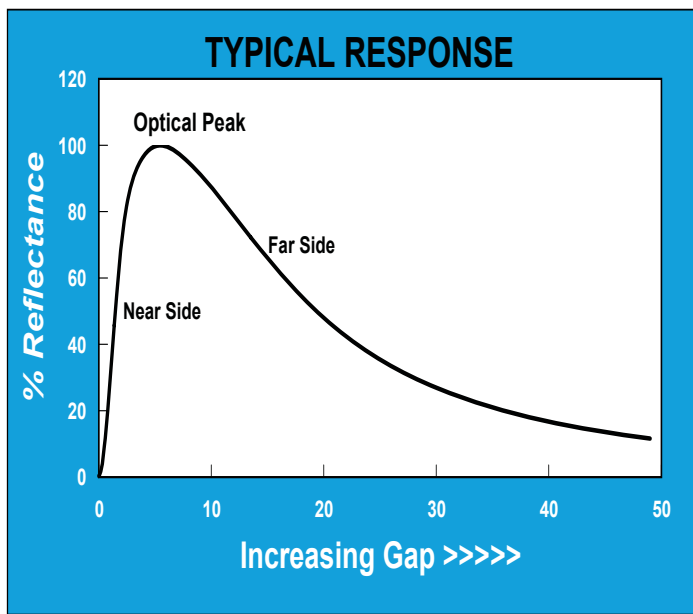

Tip & Cable Dimensions

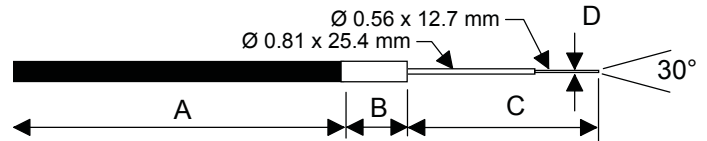

FEATURE	mm	inch
Tip Outer Diameter, \varnothing D	0.56	0.022
Fiberoptic Diameter	0.31	0.012
Tip Length, C	38.1	1.5
Collar Length, B	12.7	0.5
Collar Diameter, \varnothing B	6.35	0.25
Cable Length, A	914	36
Cable Diameter, \varnothing A	4.27	0.168
Cable Min. Bend Radius	19	0.75

*These are reflective type transducers based upon detecting the intensity of reflected light. With D Model sensors, the output signal is proportional to: a) the gap distance from the sensor tip-to-target; and, b) the reflectivity of the target surface. D models are commonly used in applications where the target reflectivity stays constant, i.e., the target has a reciprocating or vibratory motion parallel to the axis of the sensor.

PHILTEC

www.philtec.com

Precision Dynamic Measurements



Two Instrument Outputs To Choose From

This sensor can be provided as an analog or as a digital instrument. For available options and how to order go to www.philtec.com



Analog sensors are fast responding units ideal for relative motion measurements in dynamic applications:

- DC-20 KHz is standard
- DC-200 KHz or higher is optional
- DC-100 Hz provides best resolution

Standard analog units include:

- Electronics with 0 to +5 VDC output
- 3 foot long fiberoptic cable

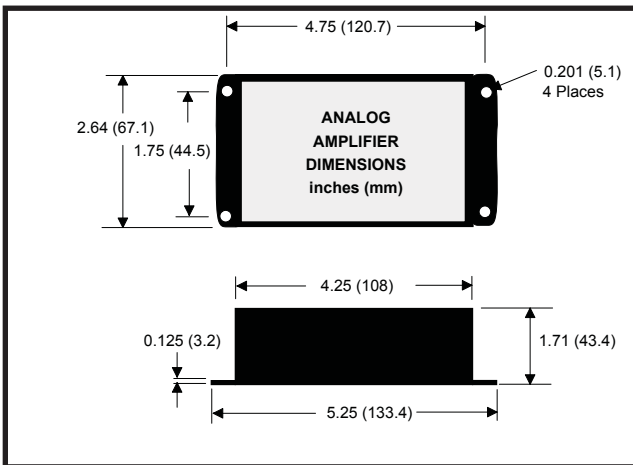

ANALOG OUTPUT

Calibration charts are provided with each sensor tip giving the near and far side voltage output responses to distance. There are three ways to derive accurate distance measurements:

- within the bounds of the linear range, multiply sensitivity by the change in voltage output
- create a lookup table using the XY calibration data points
- use a polynomial curve fit to accurately map the sensor's output function

The effect of changing target reflectance is to shift the voltage output higher or lower. A gain control is provided for calibration of the sensor output to various target surfaces. In-situ calibration is performed simply, by adjusting the sensor's tip-to-target gap until the peak output is attained, and then by using the gain control to set the peak voltage reading to full scale. This allows the sensor to be used to perform precision linear motion measurements on most materials.

Displacement Measurement Systems (DMS) are the best choice for absolute distance measurements, multiplexing and process control applications, with data rates up to 5,000 readings/second. Two sizes are available:

Standard DMS units include:

- Electronics with RS-232 communication
- Keypad/LCD for local operation

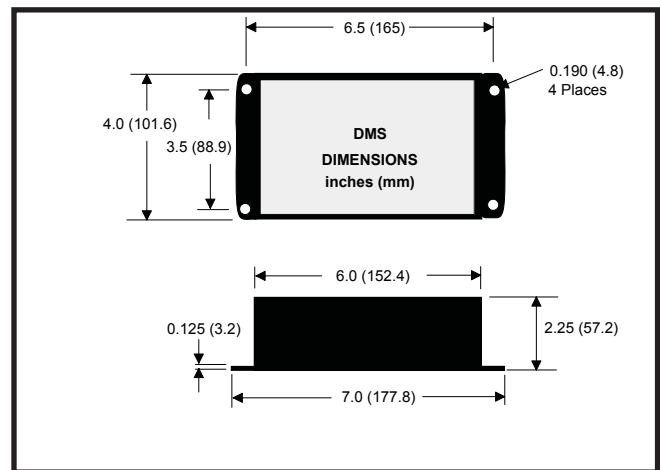

Mini-DMS units are full-featured for PC operation only, they are not equipped with keypad/display.

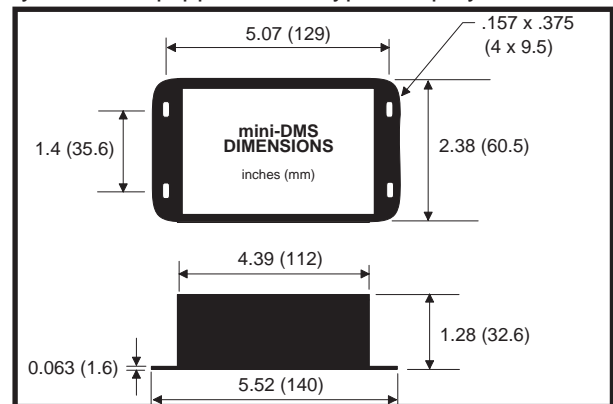

DIGITAL OUTPUT

DMS units provide distance output via RS232. Gap calibration data is stored on board DMS units. They provide accurate distance measurements over the sensor's entire operating range using a 24 bit internal lookup table. They have storage capacity for many additional calibrations.

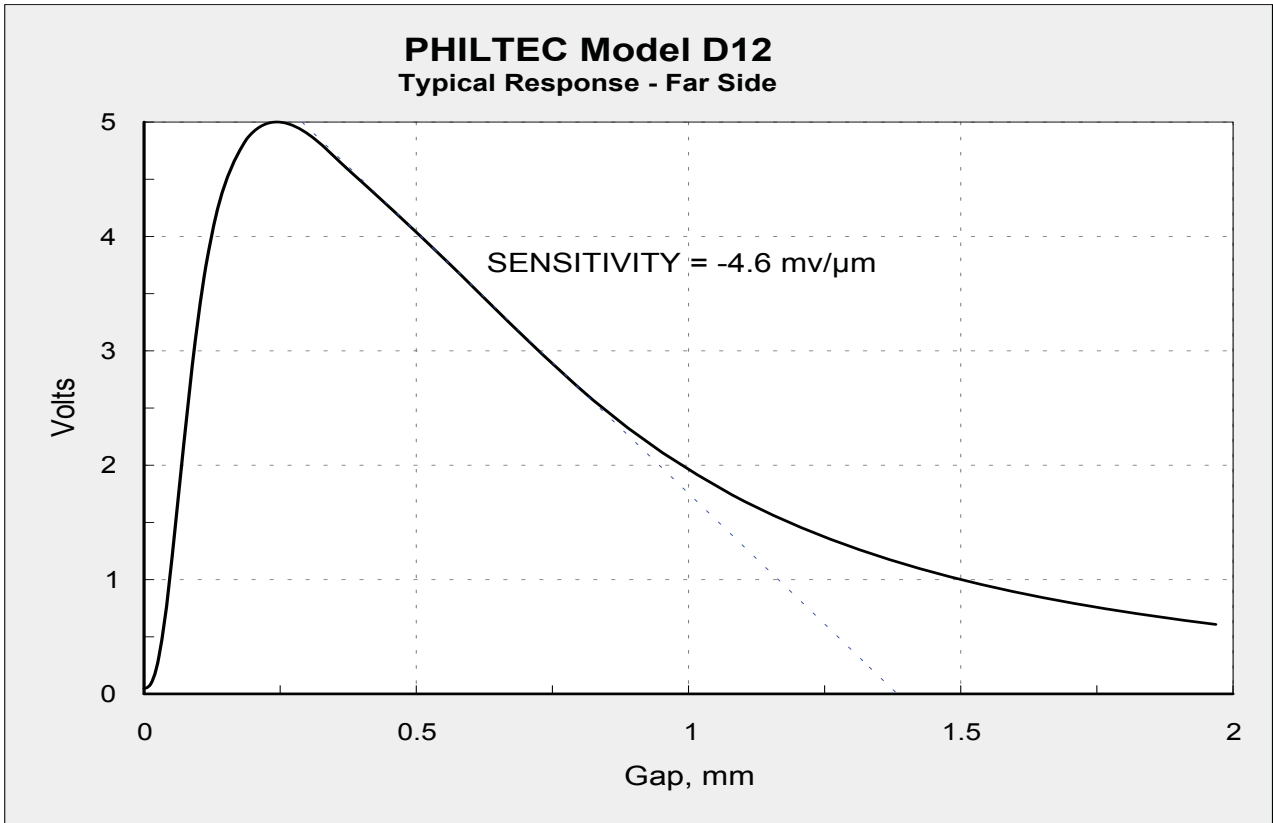

Conversions: 1 micron = 39.37 microinch 1 mm = 39.37 mils 1 mil = 0.001 inch = 25.4 microns = 0.0254 mm

Standard Specifications - D12 Far Side										
Electronics			Fiberoptics		Outputs					
	Analog	DMS	Light Beam spread	30 °	Analog Voltage			DMS RS232		
Light Source	LED, 850 nm		Cable Sheathing	PVC over Steel Monocoil	Total Range	0.080 in.	2 mm	Total Range	2 mm	
Input Voltage	+12 to +24 VDC	+12 VDC	Tip Material	300 Series SS	Linear Range	0.019 in.	0.48 mm	Distance	23 bit resolution	
Input Current	125 ma max	500 ma max	Tip Epoxy Outgas	0.3% @ 200°C 2.4% @ 300°C	Nominal Standoff	0.021 in.	0.53 mm	Reflectance	8 bit resolution	
Bandwidth	DC-20 KHz 3 db down	5 KHz max	Tip Operating Pressure	35 bar	Sensitivity	120 mv/mil	3 mv/μm	Amplifier Temperature	12 bit resolution	
Iso-thermal Drift	0.5%	0.05%	Tip Operating Temperature	-55 to 175°C continuous; to 350°C intermittent 1-2 hours	Resolution*	DC - 200KHz DC - 20 KHz DC - 100 Hz	50 μin 16 μin 1.5 μin	1.2 μm 0.4 μm 0.04 μm	Resolution* Pk-Pk Units at Mid Range using 50% Signal Power	ADC AVG = 2 pk-pk = 400 nm ADC AVG = 16 pk-pk = 250 nm ADC AVG = 256 pk-pk = 80 nm ADC AVG = 4096 pk-pk = 15 nm

*These specifications represent best case performance where: the target is flat, smooth and highly reflective, the sensor is perpendicular to the target, the sensor is gapped to its range of highest sensitivity, fiberoptic cable lengths are standard and the cables are not connectorized.

Custom Hardware To Customer Specifications

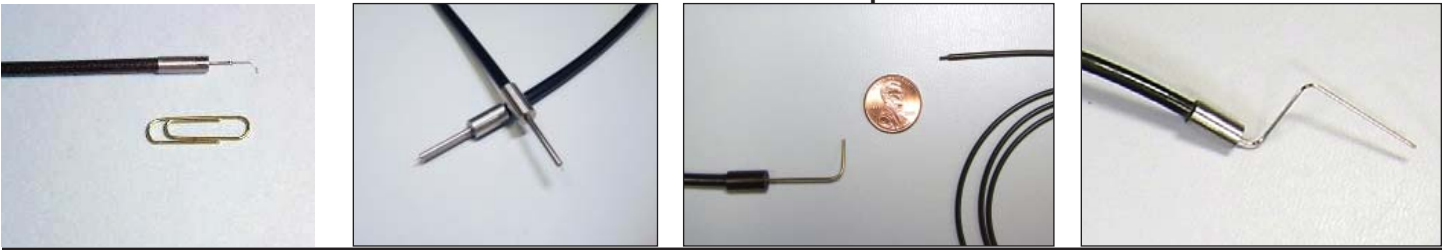

PHILTEC, INC., ANNAPOLIS, MD USA 410-757-4404
800-453-6242 e-mail sensors@philtec.com

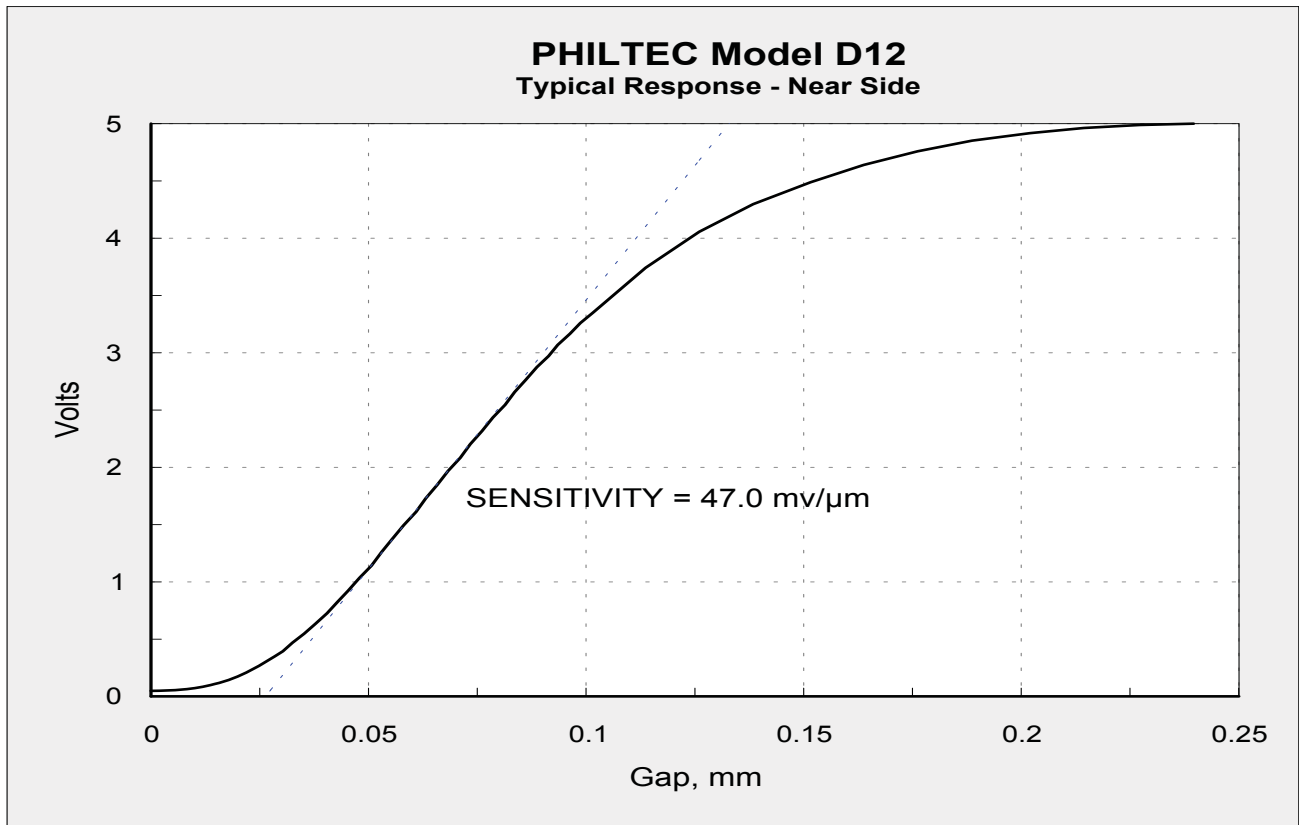

Conversions: 1 micron = 39.37 microinch 1 mm = 39.37 mils 1 mil = 0.001 inch = 25.4 microns = 0.0254 mm

Standard Specifications - D12 Near Side										
Electronics			Fiberoptics		Outputs					
	Analog	DMS	Light Beam spread	30°	Analog Voltage			DMS RS232		
Light Source	LED, 850 nm		Cable Sheathing	PVC over Steel Monocoil	Total Range	9 mils	230 μm	Total Range	230 μm	
Input Voltage	+12 to +24 VDC	+12 VDC	Tip Material	300 Series SS	Linear Range	1900 μin.	48 μm	Distance	23 bit resolution	
Input Current	125 ma max	500 ma max	Tip Epoxy Outgas	0.3% @ 200°C 2.4% @ 300°C	Nominal Standoff	3300 μin.	84 μm	Reflectance	8 bit resolution	
Bandwidth	DC-20 KHz 3 db down	5 KHz max	Tip Operating Pressure	35 bar	Sensitivity	1000 mv/mil	40 mv/μm	Amplifier Temperature	12 bit resolution	
Iso-thermal Drift	0.5%	0.05%	Tip Operating Temperature	-55 to 175°C continuous; to 350°C intermittent 1-2 hours	Resolution*	DC - 200KHz DC - 20 KHz DC - 100 Hz	4 μin 2 μin 0.2 μin	0.1 μm 0.05 μm 0.005 μm	Resolution* Pk-Pk Units at Mid Range using 50% Signal Power	ADC AVG = 2 pk-pk = 50 nm ADC AVG = 16 pk-pk = 40 nm ADC AVG = 256 pk-pk = 8 nm ADC AVG = 4096 pk-pk = 3 nm

*These specifications represent best case performance where: the target is flat, smooth and highly reflective, the sensor is perpendicular to the target, the sensor is gapped to its range of highest sensitivity, fiberoptic cable lengths are standard and the cables are not connectorized.

Many Options are Available Including Replaceable Tips, Vacuum Passthrus and Non-Metallic Tips



PHILTEC, INC., ANNAPOLIS, MD USA 410-757-4404
800-453-6242 e-mail sensors@philtec.com